



## Bohrstangenhalter Form E2

Boring bar holders form E2

Porte-outils pour barres d'alésage forme E2

DIN ISO 10889-1  
(DIN 69880)



### Verwendung:

Für Innenbearbeitung mit Bohrstangen.

### Application:

For internal machining with boring bars.

### Application:

Pour l'usinage intérieur avec barres d'alésage.

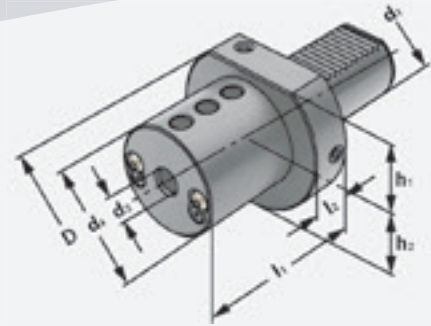

DIN ISO 10889  
(DIN 69880)

E1

Bestell-Nr. Order no. Référence	Abmessung Size Dimension	d <sub>1</sub>	d <sub>2</sub>	D	d <sub>4</sub>	h <sub>1</sub>	h <sub>2</sub>	l <sub>1</sub>	l <sub>2</sub>
169.52.06	E2 – 16 × 06	16	6	40	32	18	18	44	13
169.52.08	E2 – 16 × 08	16	8	40	32	18	18	44	13
169.52.10	E2 – 16 × 10	16	10	40	32	18	18	44	13
169.52.12	E2 – 16 × 12	16	12	40	40	18	18	44	13
169.52.16	E2 – 16 × 16	16	16	40	40	18	18	44	13
209.52.08	E2 – 20 × 08	20	8	50	40	–	23	50	18
209.52.10	E2 – 20 × 10	20	10	50	40	–	23	50	18
209.52.12	E2 – 20 × 12	20	12	50	50	–	23	50	18
209.52.16	E2 – 20 × 16	20	16	50	50	–	23	50	18
259.52.08	E2 – 25 × 08	25	8	58	40	–	25	50	18
259.52.10	E2 – 25 × 10	25	10	58	40	–	25	50	18
259.52.12	E2 – 25 × 12	25	12	58	40	–	25	50	18
259.52.16	E2 – 25 × 16	25	16	58	40	–	25	50	18
259.52.20	E2 – 25 × 20	25	20	58	58	–	25	50	–
259.52.25	E2 – 25 × 25	25	25	58	58	–	25	60	–

**Ausführung:** Mit einstellbaren Kugelspritzdüsen  
**Version:** With adjustable spray nozzles  
**Version:** Avec gicleurs ajustables

**Lieferumfang:** Mit Spannschrauben  
**Delivery:** With clamping screws  
**Livraison:** Avec vis de serrage



6.27



9.51

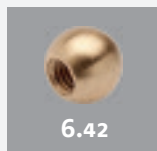

6.42